

**IT'S NAE BOTHER (J8x32) 2C (4C set)**

Carnforth Collection 4, D. Haynes

- 1- 8 1s+2s set, Ladies cross passing partners RSh & chase CW to own side
- 9-16 1s+2s dance RHX/LHX
- 17-24 1s+2s set, Men cross passing opposite Lady RSh & chase CW to own sides
- 25-32 2s+1s dance R&L

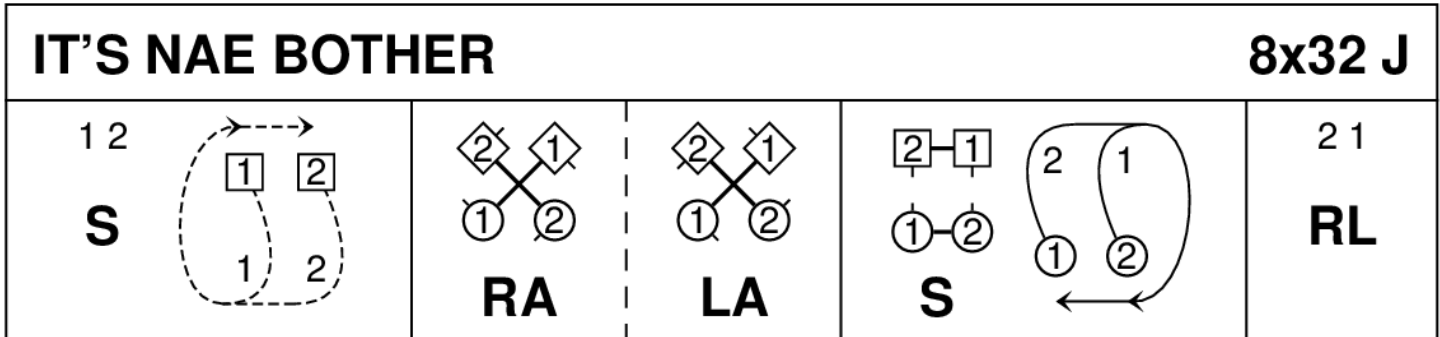

Derek Haynes, Carnforth 4, RSCDS Graded Book 2.13

2C/4C longwise set.

**PILOT'S DELIGHT (R8x32) 3C (4C set)**

T. Wilson

- 1- 8 1s turn RH, cast as 2C step up, turn LH to face 1<sup>st</sup> corners
- 9-16 1s set to corners and partner; end facing 3<sup>rd</sup> corners
- 17-24 1s+3<sup>rd</sup> corners set; 1M cast to 3L's pl & 1L cast to 1M's pl WHILE 2M+3L dance into center, pulling RSh back to end BtoB facing 1L & 1M, respectively; 1L+2M, and at same time 3L+1M, turn RH 1/2; 1s turn LH 3/4 to face 4<sup>th</sup> corners
- 25-32 Repeat with 4<sup>th</sup> corners; 1s end 2<sup>nd</sup> pl own sides

**THE BIRKS OF INVERMAY (S8x32) 3C (4C set)**

RSCDS Book 16, T. Skillern

- 1- 8 1M+2L turn 2H; 1L+2M turn 2H (3 bars) and 1s+2s+3s dance in for...
- 9-16 1s+2s+3s Promenade
- 17-24 1s cross RH, cast to 2nd pl, cross up between 2s & cast to 2nd pl (2s step up on bars 23-24)
- 25-32 2s+1s+3s circle 6H round & back

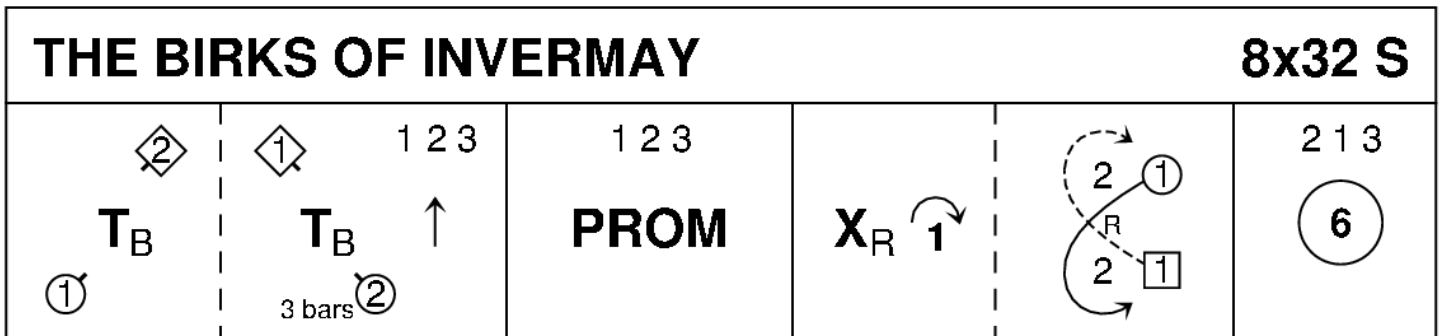

Skillern, 1789, RSCDS Book 16.2

3C/4C longwise set.

**THE FLIGHT OF THE FALCON (J8x32) 3C (4C set)**

Anniversary Tensome, B. Priddey

- 1- 8 1s set, cast as 2s step up & 1s turn LH to 1M facing his 1st corner with his partner behind him
- 9-16 1M FB partner dance a RSh diagonal Alternating Tandem Reel of 3 with 1st corners; end facing Lady's 2nd corner
- 17-24 1M FB partner dance a RSh Alternating Tandem Reel of 3 with 2nd corners; 1s end facing own 1st corners
- 25-32 1s turn 1st corners RH, pass RSh, turn 2nd corner RH, pass RSh to 2nd pl own sides (corners turn for 4 bars)

<b>THE FLIGHT OF THE FALCON</b>			<b>8x32 J</b>
	<p>Change lead at ends of reel</p>	<p>Change lead at ends of reel</p>	

Barry Priddey, Anniversary Tensome

3C/4C longwise set.

**FAIR DONALD (S8x32) 3C (4C set)**

RSCDS Book 29

1- 8 1s dance down 1 pl, cast up, dance down 2 places & cast up to face 1st corners; 2s step up on 7-8

9-16 1s dance diagonal Reel of 4 with 1st corners; pass partner LSh to face 2nd corners

17-24 1s dance diagonal Reel of 4 with 2nd corners; end in middle facing up between 2s

25-32 1s cast to 2nd pl; 2s+1s+3s set & turn partners 2H

<b>FAIR DONALD</b>				<b>8x32 S</b>

RSCDS Book 29.4

3C/4C longwise set.

**BALGEDDIE REEL (R5x32) 5C set**

Memories of Fife, M. Shoolbraid Brandon

1- 8 1M+3M set turning on the spot (hands on hips); 1L+3L dance toward partner and back to places

9-16 1L+3L FB partners cast 1 pl, dance up between couple above, cast down 1 pl (Men's side) & dance in to give RH to 1st corner and LH to partner; 2s & 4s step up when they are cast around

17-24 1s & 3s Balance-in-Line with corners, dance on to 2nd corners, Balance-in-Line, 1s & 3s 1/2 turn LH into

25-32 All dance RHX (1L with 2s, 1M and 3L with 4s, 3M with 5s); 1s and 3s 1/2 turn LH and cast down 1 pl

<b>BALGEDDIE REEL</b>			5 Couples (3C dance as 1C)		<b>5x32 R</b>

Mary Shoolbraid Brandon, 1974, Memories of Fife, Honolulu Book

5C/5C longwise set

**SANDS OF MORAR (S8x32) 3C (4C set)**

RSCDS Book 45, B. Priddey

- 1- 8 1s dance Fig of 8 round 2s giving hands when possible
- 9-16 1s dance reflection Reels of 3 on own sides (1s dance down between 2s to begin)
- 17-24 1s turn 2H, dance down to 3rd pl as 2s+3s continue reel & dance down behind 1s; all set, 1s FB 2s+3s cast up to original places
- 25-32 1s+2s dance the Tourbillon:

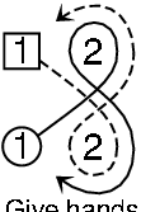
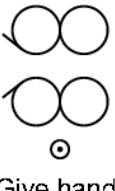
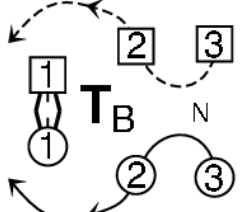
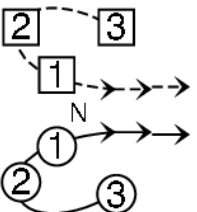
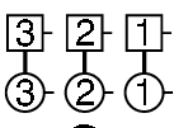
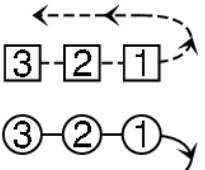
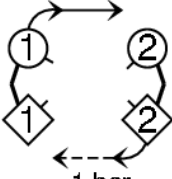
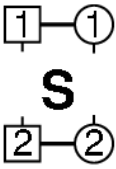
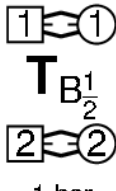
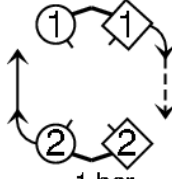
<b>SANDS OF MORAR</b>				<b>8x32 S</b>	
 <p style="font-size: small;">Give hands</p>	 <p style="font-size: small;">Give hands</p>	 <p style="font-size: small;"><b>T<sub>B</sub></b></p>	 <p style="font-size: small;"><b>N</b></p>	 <p style="font-size: small;"><b>S</b></p>	
<p style="font-size: small;">Tourbillon 1 2</p> <p style="font-size: x-large;"><b>T<sub>B</sub><sup>1</sup><sub>2</sub></b></p> <p style="font-size: small;">1 bar</p>	 <p style="font-size: small;">1 bar</p>	 <p style="font-size: x-large;"><b>S</b></p>	 <p style="font-size: small;"><b>T<sub>B</sub><sup>1</sup><sub>2</sub></b></p> <p style="font-size: small;">1 bar</p>	 <p style="font-size: small;">1 bar</p>	<p style="font-size: small;">2x 1x</p> <p style="font-size: x-large;"><b>X<sub>R</sub></b></p>



Barry Priddey, 1983, Glasgow Diamond Jubilee & RSCDS Book 45.6

3C/4C longwise set.

**IT'S ALL RIGHT (J8x32) 3C (4C set)**

2nd Book Graded SCDs, E. See

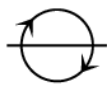
- 1- 8 1s+2s+3s set, cross RH, all chase CW ½ way
- 9-16 3s+2s+1s repeat back to places
- 17-24 1s lead down the middle & back
- 25-32 1s set, cross RH, cast as 2C step up, & cross RH

<b>IT'S ALL RIGHT</b>					<b>8x32 J</b>	
<p style="font-size: small;">1 2 3</p> <p style="font-size: x-large;"><b>S X<sub>R</sub></b></p>	<p style="font-size: small;">1x 2x 3x</p> 	<p style="font-size: small;">3 2 1</p> <p style="font-size: x-large;"><b>S X<sub>R</sub></b></p>	<p style="font-size: small;">3x 2x 1x</p> 	 <p style="font-size: small;"><b>R</b></p>	<p style="font-size: x-large;"><b>S X<sub>R</sub> 1 X<sub>R</sub></b></p>	

Elma See, RSCDS Graded Book 2.12

3C/4C longwise set.

**PEAT FIRE FLAME (R8x40) 3C (4C set)**

Bon Accord Book, J. Drewry

- 1- 8 1s cast 1 pl as 2C step up, dance ½ Fig of 8 round 2s, turn ¾ LH to face 1st corners
- 9-16 1s turn 1st corner RH, pass partner RSh, turn 2nd corner LH, pass partner LSh to face 1st corners
- 17-24 1s dance ½ diagonal Reel of 4 with 1st corners then ½ diagonal Reel of 4 with 2nd corners, end in middle BtoB facing 3rd corners
- 25-32 1s set to 3rd corners, dance round one another CW (gypsy) to face 4th corners, set, dance CW to face out opp sides
- 33-40 1s dance out, cast round 1st corner into center WHILE 2s & 3s dance ½ R&L; all turn RH

<b>THE PEAT FIRE FLAME</b>		<b>8x40 R</b>

John Drewry, 1968, Bon Accord Book

3C/4C longwise set

**THE COMPLEAT GARDENER (J8x32) 3C (4C set)**

RSCDS Graded Book 3, I. Paterson

1- 8 1s+2s Set and Rotate:

9-16 1s cross RH, cast right, cross LH up/down, cast left to end facing 1st corners

17-24 1s dance Pass and Turn with 1st corners & pass RSh to face 2nd corners; Pass and Turn with 2nd corners & pass RSh to 2nd pl own sides

25-32 2s+1s+3s circle 6H round & back

<b>THE COMPLEAT GARDENER</b>		<b>8x32 J</b>
<p>Set and Rotate</p>		
<p>Corners Pass &amp; Turn</p>		

Irene Paterson, RSCDS Graded Book 3.14

3C/4C longwise set.

**THE SKYLARKS REEL (R3x32) 3C set**

Nottingham Lace, J. Bradley

**2s start on opposite sides**

1- 8 Ladies set 2x & dance LHX while Men cast & chase CW all back to places

9-16 Men set 2x & dance RHX while Ladies cast and chase CCW to places

17-24 Reels of 3 on sides, 2s giving RSh to 3s

25-32 1s+2s set, dance RHX 1/2; 1s+3s set & dance LHX 1/2

**THE BRAES OF BREADALBANE** (S8x32) 3C (4C set)

RSCDS Book 21, T. Skillern

- 1- 8 1s turn RH, cast 1 pl as 2C step up, turn LH and 1L casts up as 1M casts down to lines of 3 across
- 9-16 1L+2s & 1M+3s set 2x, 1s cast back to 2nd places & turn RH ending on own sides
- 17-24 2s+1s+3s set 2x & turn partners 2H
- 25-32 2s+1s dance R&L

<b>THE BRAES OF BREADALBANE</b>				<b>8x32 S</b>	
			2 1 3 <b>S<sub>2</sub> T<sub>B</sub></b>	2 1 <b>RL</b>	

Skillern, 1795, RSCDS Book 21.7

3C/4C longwise set.

**KANGAROO PAW** (R8x32) 3C (4C set)

The Kangaroo Paw, J. Brenchley

- 1- 8 1s set advancing, dance down middle, Lady dances under Man's left arm to change places, 1s dance up to end BtoB in 2nd pl facing opp sides
- 9-16 1s dance Double Triangles, end facing 2nd corners
- 17-24 1s turn 2nd corner RH, turn partner LH, turn 1st corner RH, partner LH to face out 2nd pl own side
- 25-32 Reels of 3 on own sides (1s LSh to 4th corner to begin)

<b>THE KANGAROO PAW</b>				<b>8x32 R</b>	
	2 1 x 3 <b>DT</b>				

John Brenchley, 2006, The Kangaroo Paw

3C/4C longwise set.

**NEIDPATH CASTLE** (S3x32) 3C set

RSCDS Book 22, D. Haynes

- 1- 8 All set, turn partners 2H 2x, set
- 9-16 Grand Chain
- 17-24 1s dance down between 2s, cast behind 3s, dance up between 3s, cast up behind 2s; 1s+2s end ready for
- 25-32 1s+2s dance ½ Diamond Poussette, 3s dance in on bar 28 & 1s+3s dance ½ Diamond Poussette

<b>NEIDPATH CASTLE</b>			<b>3x32 S</b>	
<p>ALL</p> <p><math>\overbrace{\text{S T}_{B2} \text{S}}</math></p>	<p>ALL</p> <p><b>CHAIN</b></p>		<p>1 2</p> <p><b>P</b></p>	<p>1 3</p> <p><b>P</b></p>

Derek Haynes, RSCDS Book 22.9

3C/3C longwise set.

**ESPIE MCNABB** (J8x32) 3C (4C set)

MMM 1

- 1- 8 1s+2s+3s set, cross RH, set & cross back RH
- 9-16 1s lead down the middle & back
- 17-24 1s set, cast 1 pl as 2s step up, turn RH
- 25-32 2s+1s+3s circle 6H round & back

<b>ESPIE MCNABB</b>					<b>8x32 J</b>
1 2 3	1x 2x 3x				2 1 3
<b>S X<sub>R</sub></b>	<b>S X<sub>R</sub></b>	$\rightleftarrows$	<b>S</b> $\curvearrowright$ 1	<b>T<sub>R</sub></b>	<b>6</b>

RSCDS MMM (23)

3C/4C longwise set.

**THE MONTGOMERIES' RANT** (R8x32) 3C (4C set)

RSCDS Book 10

- 1- 8 1s cross RH, cast as 2s step up, cross LH, 1L casts up while 1M casts down
- 9-16 Reels of 3 across, 1L with 2s (RSh to 2M) & 1M with 3s (RSh to 3L); 1s end in middle facing 2L, Lady on Man's left
- 17-24 1s set to 2L, turn inwards to set to 3M, set to 3L, turn inward to set to 2M; 1s end facing own 2nd corner (1L pull back LSh to face down)
- 25-32 6 bar Reels of 3 on opp sides, 1s give RSh to 2nd corner; 1s cross RH to 2nd pl own sides

<b>THE MONTGOMERIES' RANT</b>				<b>8x32 R</b>
<p><b>X<sub>R</sub></b> <math>\curvearrowright</math> 1 <b>X<sub>L</sub></b></p>				

Castle Menzies, 1749, RSCDS Book 10.1

3C/4C longwise set.